

TECLE RACHET



RHINO HOIST CHAIN HOIST & LIFTING

CARACTERÍSTICAS TÉCNICAS

- Capacidad: Desde 0.8ton hasta 6.3ton
- Marca: Rhino Hoist
- Modelo: VIT II.

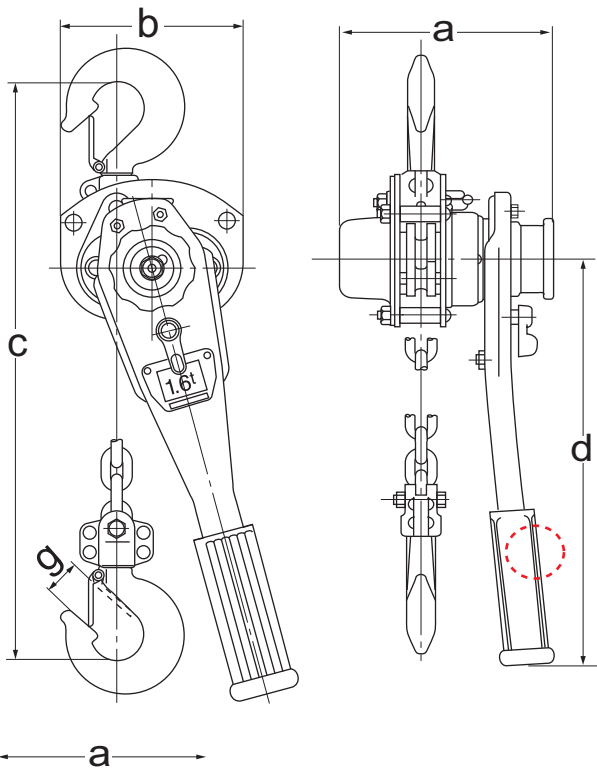

DATOS TÉCNICOS

Model Number	VITII-08	VITII-10	VITII-15	VITII-30	VITII-60	
Capacity (t)	0.8	1	1.6	3.2	6.3	
Standard Lift (m)	1.5	1.5	1.5	1.5	1.5	
Net Weight (kg)	6.9	7.1	9.7	16.3	26.7	
Min.Distance between Hooks (mm)	295	310	335	405	550	
Pull Required to Lift Full Load	(kgf)	15	20	18	38	39
	(N)	147	196	177	373	382
Chain thickness (mm)	6.3	6.3	7.1	9.0	9.0	
Dimension	a (mm)	148	148	163.5	191	191
	b (mm)	128	128	148	181	244
	c (mm)	295	310	325	395	550
	d (mm)	256	256	368	368	368
	g (mm)	27	30	34	43	47

